

**GENERAL PUMP** *A member of the Interpump Group*

# YU831/YU815 YU831RK/YU815RK

*Unloader Valves*

**SPECIFICATIONS**

Part Number	YU831	YU815
		<b>YU831RK</b>
		<b>YU815RK</b>
Maximum Pressure	YU831(RK)	3650 PSI
	YU815(RK)	1750 PSI
Maximum Flow	8 GPM	
Temperature	195 °F	
Port Sizes:	Inlet	3/8" NPT-F (1)
	Discharge	3/8" NPT-F (1)
	Bypass	3/8" NPT-F (1)
Dimensions	6.4" x 2.7" x 1.6"	
Shipping Weight	1.9 lbs	
Materials	Brass, Stainless, Buna-N, Plastic	



*General Pump recommends using a safety relief valve device in conjunction with this unloader valve when installed on a positive displacement pump. General Pump is not liable and assumes no responsibility for this valve when used in a customer's high pressure system.*

**PARTS LIST**

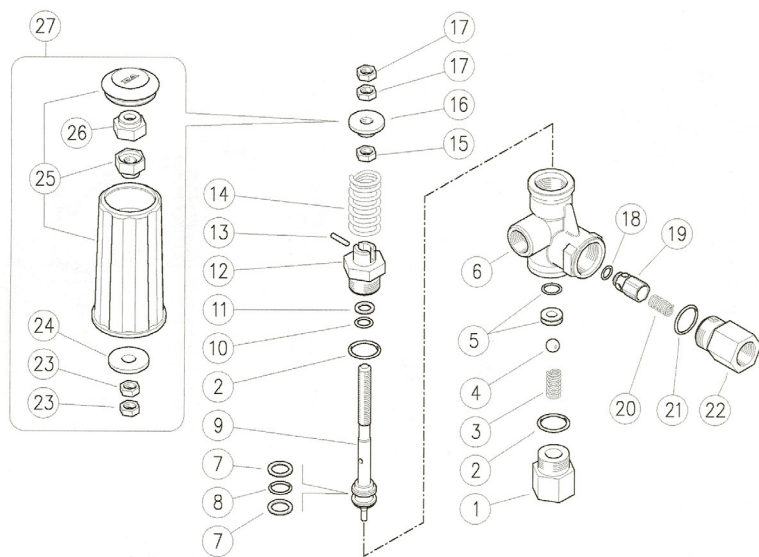

Item	Part Number	Description	Kit	Qty
1	60003031	3/8 NPT Inlet Fitting		1
2	10306800	O-ring, 1.78 x 17.17 mm	KIT 178	2
3	60001551	SS Spring		1
4	14744310	SS 11/32" ball	KIT 178	1
5	300031201	7 mm seat + O-ring bag	KIT 178	1
6	60008635	3/8 NPT Brass Body		1
7	10402100	Back Ring, 11.4 x 15.9 mm	KIT 178	2
8	10317500	O-ring, 2.62 x 10.77 mm	KIT 178	1
9	60006123	SS Piston		1
10	10317000	O-ring, 2.62 x 7.6 mm	KIT 178	1
11	10402000	Back Ring, 8 x 12.6 mm	KIT 178	1
12	60006431	Piston Housing		1
13	15102100	Pin, 3 x 14 mm		1
14	60001261	White Spring		1
14	60003361	Blue Spring		1
15	11457631	Brass Nut, M, 8 x 6 mm		1
16	60001131	Spring Guide		1
17	11457400	Nut, M8		2
18	10321300	O-ring, 3 x 6 mm	KIT 178	1
19	60005231	Check Valve		1
20	60005351	Spring		1
21	10307002	O-ring, 1.78 x 18.77 mm	KIT 178	1
22	60005931	Outlet Fitting, 3/8 NPT		1
23	11457331	Brass Nut, M8		2
24	14372040	Washer, 8 x 24 mm		1
25	60000424	Knob Assembly		1
26	11458910	Nut, M8		1
27	60001424	Complete Knob		1

# YU831(RK)/YU815(RK) **GENERAL PUMP** A member of the Interpump Group

## APPLICATION

This product is to be used with clean, fresh water. For different or corrosive liquids, contact **GP Companies Inc.** technical support department. Appropriate filtration should be installed when used with liquids containing any solids. Select the proper unloader valve based on the nominal operating rating: system rated pressure, max flow and max temperature. **Under no circumstances should the pressure of the system exceed the maximum rated pressure of any component.**

## INSTALLATION

When installed on hot water cleaners, this valve is to be installed **before** the boiler. Installing safety devices which limit the accidental increase of the fluid temperature is required.

**Always** install a safety valve (pop-off) to protect the operator and system.

## UNLOADER ADJUSTMENT

### READ AND UNDERSTAND THESE INSTRUCTIONS PRIOR TO USE

**DO NOT ATTEMPT TO ADJUST THE UNLOADER WITHOUT A PRESSURE GAUGE INSTALLED ON THE SYSTEM!**

Choose the correct nozzle size, able to discharge regularly, on bypass, at least 5% of the total flow of the system in order to achieve a constant pressure, and avoid troublesome pressure spikes. On installation of a new nozzle, readjust the system to the original pressure setting.

## OPERATION

The valve regulates the max pressure of the system through a piston, which acts on a ball correctly positioned, which then closes the bypass opening. A check valve cuts out the delivery section, the pressure of which controls the drive of the piston. Each regulation should be made when the system is operational and the nozzle open.

**VERSION WITHOUT KNOB:** after adjusting the valve to the set pressure, tighten the nut (item 15) and mark it with a drop of paint.

**VERSION WITH KNOB:** tighten the two nuts (item 23) to delimit the max pressure and set up the locknut (item 26) to stabilize the minimum pressure.

**ATTENTION:** Removing the nuts (items 15 and 23) could result in serious injury to the operator and/or the pump.

## MAINTENANCE

Standard: Every 400 working hours check and lubricate seals with water resistant grease.

Special: Every 800 hours replace the seals and internal parts with genuine GP parts, taking care during installation to lubricate with water resistant grease.

**ATTENTION:** Reassemble the valve in the correct order, paying special attention to the nuts (items 15 and 23, by fastening them with a drop of glue. The manufacturer is not responsible for damage resulting from incorrect maintenance and fitting.

## TROUBLESHOOTING

### PROBLEM

Frequent unloader recycles

### PROBABLE CAUSES

Damaged check valve O-ring  
Leaking connections  
Restricted bypass

### SOLUTIONS

Replace  
Check and tighten  
Clean

Unloader does not reach pressure

Unloader not properly sized  
Piston O-rings worn out  
Debris between seat and shutter  
Worn out nozzle

Change spring or type of valve  
Replace  
Clean the seat  
Replace

Pressure spikes

There is not a 5% min. of total flow in bypass  
Excessive flow in bypass  
Spring totally compressed

Reset  
Change type of valve or adjust  
Loosen knob and change nozzle

Unloader does not bypass at low pressure

Jammed check valve  
Check valve O-ring worn out  
Debris on check valve

Clean or replace  
Replace  
Clean